



# Cone Ranger

## Transportable Cone Crushers



Quality Engineered  
Excellence Since 1911

# Parker 'ConeRanger' CP Series

The Parker 'ConeRanger' CP is a crushing unit designed to operate in a secondary or tertiary role. The transportable chassis offers easy transportation between locations and rapid on-site set up. Incorporating the well proven fully hydraulic Parker Cone Crusher, this unit is ideal for working in a composite crushing arrangement with Parker primary crushing plants, screens and conveyors.

Cone Ranger Model	Machine Size	Power to Drive Crusher (kW)	Weight (tonnes)	Dimensions (mm)			
				A	B	C	D
CP900	900	75	14.7	4620	3750	3150	2240
CP1200	1200	110	23.5	5460	4160	3560	2470
CP1350	1350	150	28.5	5550	4468	3868	2680

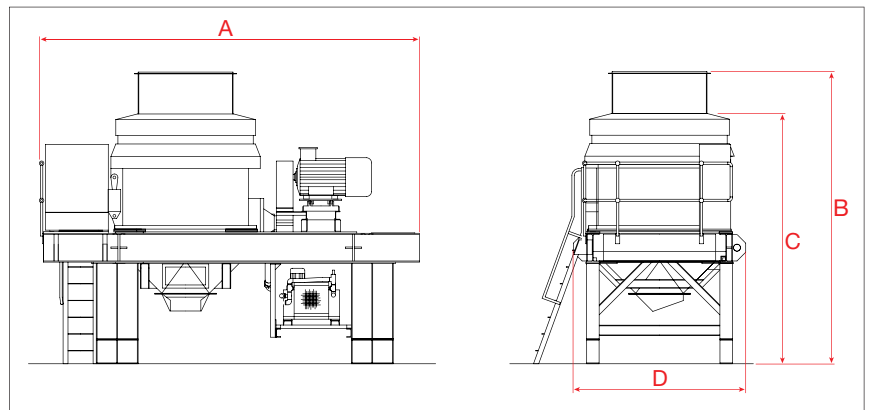

Size	Cavity	Recommended Minimum Discharge Setting (mm)	Feed Opening (mm)		Crusher Closed Side Setting (mm) Recommended Range										Maximum Jaw Setting (mm)			
			Open Side	Closed Side	6	8	10	12	15	20	25	30	35	40		50		
900	Extra Fine	6	45	30	55	65	70	80										
	Fine	8	65	45		70	80	85	95									
	Medium Fine	10	85	65			80	90	100	115								
	Medium	12	115	95				95	105	120	135	150						65
	Medium Coarse	15	150	130					110	125	140	165	190					75
	Coarse	25	180	165							150	170	195	220				115
	Extra Coarse	30	215	200								180	210	235				125
1200	Extra Fine	6	75	55	85	95	100	110										
	Fine	8	90	65		100	105	120	130									
	Medium Fine	12	115	90				130	145	165	180							
	Medium	15	145	135					150	170	195	225						115
	Medium Coarse	20	170	155						175	205	230	265	300				125
	Coarse	25	210	195							210	240	275	315	350			140
	Extra Coarse	30	250	230								255	290	340	380			150
1350	Extra Fine	6	75	55	120	130	145	160										
	Fine	10	100	75			150	170	190	200								
	Medium Fine	15	125	95					200	220	235	250						
	Medium	20	160	145						225	245	290	320					125
	Medium Coarse	25	210	190							260	300	340	380				150
	Coarse	30	250	230								330	370	415	455			180
	Extra Coarse	35	280	260									400	445	490			200

**NOTE:** Capacities quoted are intended as a guideline only, and are based on a clean, dry graded continuous feed material (weighing 1600kg/m<sup>3</sup> (100lb/ft<sup>3</sup>) and a S.G of 2.7 average), which will readily enter the crusher feed opening without obstruction. Actual capacities can vary considerably from those given, due to the following application and operational factors: 1) **MATERIAL** - Friability & Toughness, 2) **FEED CONDITIONS** - Grading of feed size (Compliance with Euro STD). 3) **INSTALLATION** - Method of feeding, Removal of under size. [Operation at settings outside those stated should be referred to the works].

Parker Plant Limited, Viaduct Works, Canon Street, Leicester, LE4 6GH, United Kingdom

T: +44 (0) 116 266 5999 F: +44 (0) 116 266 4422 W: [www.parkerplant.com](http://www.parkerplant.com) E: [sales@parkerplant.com](mailto:sales@parkerplant.com)

All reasonable steps have been taken to ensure the accuracy of this publication. However, due to our policy of continual product development, Parker Plant Limited reserve the right to change details without prior notice. All machines supplied in accordance with our standard conditions. Illustrations and photos may show optional equipment.