



GC1000

Tracked Cone Crusher



Quality Engineered
Excellence Since 1911

Parker Tracked Cone Crusher GC1000

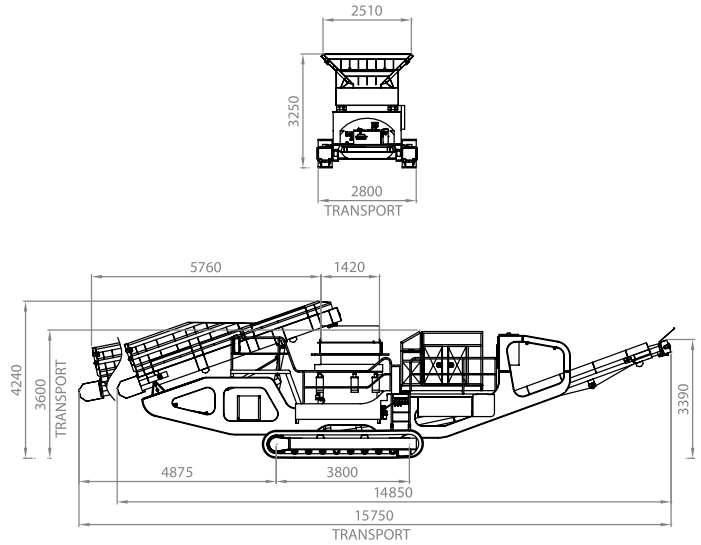

Belt Feeder

Feeding the material into the Cone Crusher is a belt feeder. Contained under the loading area are impact rollers for loading shock absorption while the heavy-duty feeder belt feeds the cone via a hydraulic variable speed drive motor. Fitted into the conveyor is a metal detector to protect the cone from tramp metal.

Feed Hopper

The feed hopper is manufactured from Hardox 400.

Track Frame

The track is manufactured from heavy-duty frame steel having 3.8m longitudinal centres along with 400 wide tracks as a standard with an overall track width of 2.8m.

Product Transfer Chute

Fitted beneath the cone is the product transfer chute. This chute transfers the material passing the cone setting onto the forward product conveyor.

Forward Product Conveyor

The forward product conveyor or main conveyor is a 1200mm wide, troughed belt conveyor with a fixed tail section and a discharge height of 3.2m. The belt is driven via a hydraulic drive motor.

Power Pack

CATERPILLAR model C9 engine with electronic governing and emission control powers the plant. Rated at 300 bHP continuous (225kW) @ 2000 rpm designed to drive the cone via a KPTO transmission.

Cone

Parker is able to produce a machine with a unique combination of providing higher capacity and superior product quality. With proven revolutionary designs, the cones provide unbeatable performance on secondary, tertiary and quaternary applications and help achieve the highest possible levels of profitability. The cone offers the highest capacities for their size in the industry. Technology allows the ability to operate at a fixed mechanical setting – instead of the head floating on a column of hydraulic oil - creates less drift and provides more stability throughout the circuit. These series of cone crushers enable the customer to produce a finer product with fewer crushing stages, lowering the capital costs and the amount of waste and also energy. The cone offers such features dual-acting hydraulic tramp release cylinders, large clearing stroke, self-tightening helix on the upper section of the bowl liner and self-tightening lock bolts on the mantle. Hydraulic motors rotate the bowl for fine control setting adjustments with high performance, non contacting labyrinth seals providing high reliability by keeping out dust without wearing out. There is excellent wear protection for all components on the crusher. The head ball, mainframe seat liners, mainframe pin bushings, countershaft box frame ring, counterweight guard, mainframe liners and dead-bed feed hopper are all replaceable items, keeping maintenance costs to a minimum.

Options

Special features are available depending on the client's requirements. Engine fire suppression, dust suppression, optimax feed controller.

NOTE: Capacities quoted are intended as a guideline only, and are based on a clean, dry graded continuous feed material (weighing 1600kg/m³ (100lb/ft³) and a S.G of 2.7 average), which will readily enter the crusher feed opening without obstruction. Actual capacities can vary considerably from those given, due to the following application and operational factors: 1) **MATERIAL** - Friability & Toughness, 2) **FEED CONDITIONS** - Grading of feed size (Compliance with Euro STD), 3) **INSTALLATION** - Method of feeding, Removal of under size. [Operation at settings outside those stated should be referred to the works].

Parker Plant Limited, Viaduct Works, Canon Street, Leicester, LE4 6GH, United Kingdom

T: +44 (0) 116 266 5999 F: +44 (0) 116 266 4422 W: www.parkerplant.com E: sales@parkerplant.com

All reasonable steps have been taken to ensure the accuracy of this publication. However, due to our policy of continual product development, Parker Plant Limited reserve the right to change details without prior notice. All machines supplied in accordance with our standard conditions. Illustrations and photos may show optional equipment.