



CrushRanger 1208

Mobile Crushing & Screening



Quality Engineered
Excellence Since 1911

Parker 'CrushRanger' Series 1208

The 'CrushRanger' 1208 is a mobile single-unit closed-circuit plant for screening and crushing virgin aggregates, providing a product down to minus 12mm in up to three sizes. At the feed point a reciprocating tray feeder, with feed hopper mounted over it, supplies material to the main feed conveyor, which discharges onto a four deck 'Rapide' screen, Rejects from the two top decks are crushed by a 'Rocksizer' jaw crusher and 'Rollsizer' crushing rolls, and the crushed product is returned to the feed conveyor by a returns conveyor and 'Ringovator' elevating ring for further screening. The two lower decks of the screen produce three product sizes which are delivered by belt conveyors for truck loading or stockpiling.

Model shown below: CrushRanger 1208 E3D

Key:

- | | | |
|-------------------------------|-------------------------------|----------------------|
| 1 - Feed Hopper | 5 - Roll-Sizer Crushing Rolls | 9 - Returns Conveyor |
| 2 - Reciprocating Tray Feeder | 6 - RockSizer Jaw Crusher | 10 - Ringovator |
| 3 - Screen Feed Conveyor | 7 - Forward Product Conveyor | |
| 4 - Rapide Screen | 8 - Side Product Conveyor | |



DIMENSIONS IN METERS

Model	A		B	C	D	E	F	G
	Working	Travelling						
1208	16.5	13.31	4.9	2.87	3.75	3.45	3.30	6.40

APPROXIMATE HOURLY CAPACITIES

Model	Material	<12mm	<25mm	<40mm
		tonne/hr		
1208	Sand & Gravel	80-100	100-140	180-220
	Crushed Rock	60-65	65-70	85-100

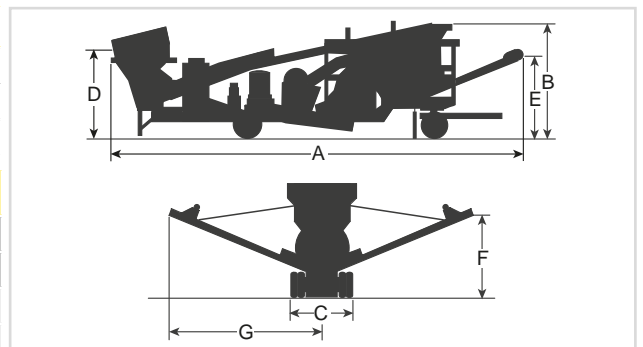

DATA

Model	Feed Hopper Capacity	Size of Crusher 'RockSizer'	Size of Crushing Rolls	Screen Size	BELT WIDTH OF CONVEYORS				POWER TO DRIVE								Approximate Weight		
					Screen Feed	Returns	Forward	Side Stockpiling	Reciprocating Tray Feeder	Screen Feed Conveyor	4 Deck 'Rapide' Screen	'RockSizer' Jaw Crusher	'RollSizer' Crushing Rolls	Returns Conveyor	Forward Conveyor	Side Stockpiling	tonnes	lbs	kilos
					m ³	mm				kW									
1208	3.0	950 x 300	600 x 600	1200 x 3000	750	600	600	500	4.0	5.5	11.0	45.0	55.0	4.0	4.0	2.2	30.0	66,000	29,940

NOTE: Capacities quoted are intended as a guideline only, and are based on a clean, dry graded continuous feed material (weighing 1600kg/m³ (100lb/ft³) and a S.G. of 2.7 average), which will readily enter the crusher feed opening without obstruction, with 100% greater than the jaw setting and 25% less than twice the jaw setting. Actual capacities can vary considerably from those given, due to the following application and operational factors: 1) **MATERIAL** - Friability & Toughness, 2) **FEED CONDITIONS** - Grading of feed size (Compliance with Euro STD), 3) **INSTALLATION** - Method of feeding, Removal of under size. [Operation at settings outside those stated should be referred to the works].

Parker Plant Limited, Viaduct Works, Canon Street, Leicester, LE4 6GH, United Kingdom

T: +44 (0) 116 266 5999 F: +44 (0) 116 261 0812 W: www.parkerplant.com E: sales@parkerplant.com

All reasonable steps have been taken to ensure the accuracy of this publication. However, due to our policy of continual product development, Parker Plant Limited reserve the right to change details without prior notice. All machines supplied in accordance with our standard conditions. Illustrations and photos may show optional equipment. All rights reserved.