



CrushRanger 1301

Mobile Crushing & Screening



Quality Engineered
Excellence Since 1911

Parker 'CrushRanger' Series 1301

This two-stage, closed circuit crushing, screening and stockpiling outfit normally produces three product sizes at outputs of up to 45 tonnes/hr. (See capacity table) The primary 'RockSizer' jaw crusher discharges on to a belt conveyor feeding the three deck Parker 'Rapide' screen. Oversize from the screen is chuted to the 'StoneSizer' jaw granulator for further reduction, then returned by belt conveyors to the screen.

All drives are by individual electric motors, where mains supply is not available, a diesel powered generator can be supplied. (100kW/125kVA)

Feed Unit: Optional (but recommended) 4.25m³ nominal capacity hopper with

630mm wide vibrating feeder including grizzly section, (separating out fines to by-pass the crusher) and 4.0kW cage motor, wiring and plug/socket connection.

Jaw Crushers: The 'RockSizer' primary jaw crusher and the 'StoneSizer' jaw granulator are single-toggle upthrust machines with easily adjusted jaw setting. Each is complete with matched pulley and flywheels, steel feed and discharges chutes, and drive by individual slip-ring electric motor and vee ropes.

Feed & Return Conveyors: These belt conveyors are complete with steel feed boot and discharge chute, each with drive by electric torque-arm gearbox and vee ropes.

Vibrating Screen: The Parker 3 deck 'Rapide' screen is supplied with a set of standard screen meshes, sized for application. Drive is high-torque electric motor and vee ropes. Two screened products and fines are directed by chutes for collection by plant-mounted or free-standing stockpiling conveyors. A split bottom neck is available to provide a fourth product together with an additional stockpiling conveyor.

Model shown below CrushRanger AD1301 E3D

Key:

- 1 - Feed Hopper
- 2 - Vibrating Feeder
- 3 - RockSizer Jaw Crusher
- 4 - Screen Feed Conveyor
- 5 - Rapide Screen
- 6 - StoneSizer Jaw Crusher
- 7 - Forward Product Conveyor
- 8 - Side Product Conveyor Chute
- 9 - Returns Conveyor
- 10 - Control Panel



DIMENSIONS (mm)									
Model	A		B	C	D	E	F	G	H
	Working	Travelling							
1301	16600	14000	4800	2860	4000	3250	3150	8650	3060

APPROXIMATE HOURLY CAPACITIES				
Model	Max Feed Size m ³	<12mm	<25mm	<40mm
		t/h		
1301	280	20-30	25-40	30-50

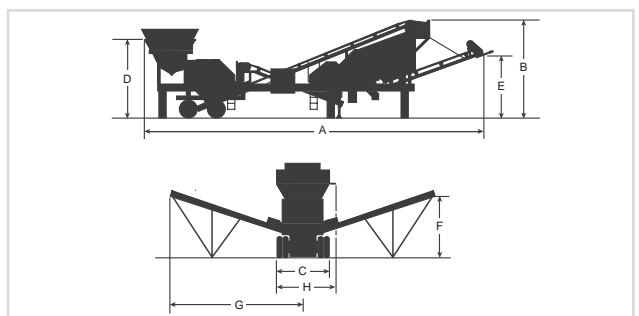

DATA																			
Model	Feed Hopper Capacity	Size of Crusher 'RockSizer'	Size of Granulator 'StoneSizer'	Size of Screen	BELT WIDTH OF CONVEYORS				Power to Drive							Approximate Weight			
					Screen Feed	Returns	Forward	Side Stockpiling	Reciprocating Tray Feeder	'RockSizer' Jaw Crusher	Screen Feed Conveyor	3 Deck 'Rapide' Screen	'StoneSizer' Jaw Crusher	Returns Conveyor	Forward Conveyor				Side Stockpiling
					m ³	mm	mm	mm	mm	mm	mm	mm	mm	mm	mm	mm	mm	mm	mm
1301	4.25	600 x 300	600 x 150	1200 x 3000	500	400	400	400	4.0	30.0	3.0	7.5	30.0	2.2	2.2	2.2	16.0	35,200	15,970

NOTE: Capacities quoted are intended as a guideline only, and are based on a clean, dry graded continuous feed material (weighing 1600kg/m³ (100lb/ft³) and a S.G. of 2.7 average), which will readily enter the crusher feed opening without obstruction, with 100% greater than the jaw setting and 25% less than twice the jaw setting. Actual capacities can vary considerably from those given, due to the following application and operational factors: 1) **MATERIAL** - Friability & Toughness, 2) **FEED CONDITIONS** - Grading of feed size (Compliance with Euro STD), 3) **INSTALLATION** - Method of feeding, Removal of under size. [Operation at settings outside those stated should be referred to the works].

Parker Plant Limited, Viaduct Works, Canon Street, Leicester, LE4 6GH, United Kingdom

T: +44 (0) 116 266 5999 F: +44 (0) 116 261 0812 W: www.parkerplant.com E: sales@parkerplant.com

All reasonable steps have been taken to ensure the accuracy of this publication. However, due to our policy of continual product development, Parker Plant Limited reserve the right to change details without prior notice. All machines supplied in accordance with our standard conditions. Illustrations and photos may show optional equipment. All rights reserved.